

MODELS

ES750	ES1500
ES1000	ES1800
ES1300	ES2200

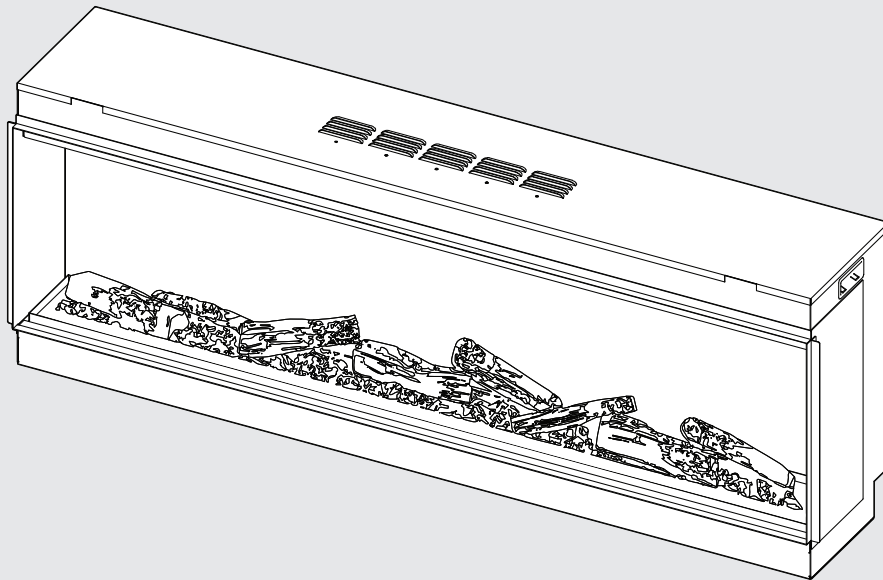

Electric Fire Heater

Operation & Installation Manual

Rinnai

Congratulations on the purchase of your Rinnai Electric Fire Heater. We trust you will have many years of comfort and enjoyment from your appliance.



BEFORE USING THIS APPLIANCE.

Before proceeding with the operation or installation of your new heater, please read this manual thoroughly and gain a full understanding of the requirements, features and operation of your new appliance.

This appliance must be installed in accordance with Manufacturer's Installation Instructions.

For continued safety of this appliance it must be installed and maintained in accordance with the manufacturer's instructions.

Before proceeding with the operation or installation of your new heater, please read this manual thoroughly and gain a full understanding of the requirements, features and operation.



OPERATION TABLE OF CONTENTS

Operation	7
Manual Control	7
On/Off	7
Wi-Fi On/Off	7
Standby	7
Heat Mode	7
Preset Mode	7
Remote Control	8
Remote Control Setup	8
Button 1: Preset Mode	8
Button 2: Standby.....	8
Button 3&9: Minus (–) & Plus (+)	9
Button 4: Flame Speed	9
Button 5: Flame Colour	9
Button 6: Fuel Bed Colour	9
Button 7: Timer Mode	9
Button 8: Fuel Bed Downlight	9
Button 10: Heater Mode	10
Button 11: Sound Effect	10
Button 12: Ambient Lighting (Not available)	10
Button 13: Eco Mode	10
Wi-Fi	10
CLEANING & REPAIRS	11
Cleaning	11
Repairs	11
Trouble Shooting Checklist	11
Resetting the Thermal Cut Out	11
Installation Table of Contents	12
Contacts	28

WARNINGS AND IMPORTANT INFORMATION



READ ALL INSTRUCTIONS BEFORE USING THE APPLIANCE.

Always comply with the following precautions to avoid dangerous situations and to ensure optimum performance.

Failure to carefully read and follow all instructions in this manual can result in equipment malfunction, property damage, personal injury and/or death.

DANGER: Indicates an imminently hazardous situation which, if not avoided, will result in personal injury or death.

WARNINGS: Indicates a potentially hazardous situation which, if not avoided, could result in personal injury or death.

CAUTIONS: Indicates a potentially hazardous situation which, if not avoided, could result in minor or moderate injury or damage to the appliance. It may also be used to alert against unsafe practices.



REGULATORY / INSTALLATION

This appliance must be installed in accordance with Manufacturer's Installation Instructions.

The appliance is intended only for domestic heating applications, and not intended for non-domestic and commercial applications. It is important that the following precautions are followed to minimise the risk of overheating, fire, electric shock and injury.

Handle the appliance with care, avoid vibrations and knocks. Unpack the appliance and check for damage. **DO NOT INSTALL A DAMAGED APPLIANCE.** If the appliance is damaged or defective, contact your supplier for advice, the appliance may **ONLY** be serviced by the manufacturer or the manufacturer's agent or similarly qualified person.

DO NOT install or use the appliance if the power cord is damaged. If it is damaged or requires replacing, it **MUST** be replaced by the manufacturer or the manufacturer's agent or similarly qualified person.

The heater is fitted with an Australian flexible cord and 3 pin plug intended for connection to an Australian 240 V, 50 Hz, 10 Amp, earthed socket outlet supplied from mains electricity. It is not suitable for connection in other countries or alternative power supplies. Ensure that the voltage and frequency of the power supply correspond to the ratings on the dataplate of the appliance.

DO NOT use power boards, double adaptors or extension leads for this appliance.

The 3 pin plug must remain accessible after the appliance is installed. The heater **MUST NOT** be located below an electric socket outlet. The connection of the appliance to a permanent electrical supply (hard-wiring) and the installation of any other electrical wiring, power outlets and switches **MUST** be performed by a person authorised under the legislation of your local electrical authority, such as a licensed electrician.

DO NOT connect the appliance to the mains power until it has been installed in its final location and adjusted to the position it will be used in.

DO NOT handle any parts of the heater, including the plug and flexible cord, with wet or damp hands.

DO NOT immerse the appliance, flexible cord and plug in water or any other liquid.

DO NOT place containers of any liquid or wax on the heater.

This appliance is suitable for indoor use only.

Never dismantle the appliance. Tampering with electrical connections and components is highly dangerous and may cause appliance malfunction. Repairs to be performed only by a qualified person such as an electrician.

The flexible cord and plug **MUST** not be modified. If the cord or plug are damaged, they **MUST** be replaced by Rinnai or a Rinnai appointed service agent.



This appliance **MUST NOT** be installed where curtains or other combustible materials could come into contact or in close proximity with it. In some cases curtains may need restraining.

DO NOT place articles or on or against this appliance any parts of this heater, to avoid overheating.

DO NOT sit on this heater.

DO NOT place any items of clothing, hand towels or similar over the appliance to dry.

DO NOT spray aerosols in the vicinity of this appliance whilst the appliance is operating. Most aerosols contain flammable gas, which can be a fire hazard if used near the appliance when it is in use.

DO NOT use or store flammable materials, liquids, etc. near this appliance. Combustible materials **MUST** not be placed where the appliance could ignite them.

DO NOT use the appliance in areas where the presence of flammable dust particulates may cause an explosion.

This appliance is intended only for domestic heating applications. It is **NOT** intended for non-domestic or commercial applications.

DO NOT use the appliance as a sauna heater.

DO NOT leave the appliance unattended whilst in operation.

CAUTION when being operated the surfaces of this appliance will get **VERY HOT - DO NOT TOUCH ANY PART OF THE APPLIANCE WHILE IT IS TURNED ON**. To avoid burns, **DO NOT** touch the any surface of the appliance with any body part.

The appliance will retain significant heat for a period after shut down. To avoid burns, **DO NOT** touch the any surface of the appliance with any body part during this period.

This appliance is not intended for use by persons (including children) with reduced physical, sensory or mental capabilities or lack of experience and knowledge, unless they have been given supervision or instruction concerning use of the appliance by a person responsible for their safety and have the capacity to follow those instructions.

The appliance is not intended for use by young children or infirm persons without supervision.

Young children should be supervised when in the vicinity of this appliance while it is in operation to ensure they **DO NOT** play with the appliance.

DO NOT allow children or persons with reduced physical, sensory or mental capabilities to sleep directly in front of the heater.

DO NOT allow children to 'post articles' into the louvres of the heater.

NO USER SERVICEABLE PARTS - NEVER dismantle the appliance. Tampering with electrical connections and components is highly dangerous and can result in equipment malfunction, property damage, personal injury and/or death. Repairs to be performed only by a qualified person such as an electrician.

DO NOT modify this appliance. Modifying from original specifications may create a dangerous situation and will void your warranty.

DO NOT use this heater if it has been dropped.

DO NOT use if there are visible signs of damage to the heater.

DO NOT use this heater in small rooms when they are occupied by persons not capable of leaving the room on their own, unless constant supervision is provided.

To reduce the risk of fire, keep textiles, curtains, or any other flammable material a minimum distance of 1 m from the air outlet.



NOTE TO INSTALLERS AND CONSUMERS

Please leave this operation and installation manual, suction cups and magnetic tools in a handy place for future use.



MANDATORY INSPECTION PRIOR TO INSTALLATION

Immediately report any damage or discrepancies to your appliance supplier. This appliance has been inspected and tested at the time of manufacture and packaging, and was released for transportation without known damage. Upon receipt, inspect the exterior for evidence of rough handling in shipment. Ensure that the appliance is labelled correctly for the electrical supply it is intended to be connected to.

For safety and warranty purposes, appliances that may be damaged or incorrect **MUST NOT** be installed or operated under any circumstances. No responsibility will be accepted for installation or operation of damaged or incorrect appliances. Installation of damaged or incorrect appliances may also contravene local regulations.



A NOTE ON ILLUSTRATIONS

The illustrations used in this manual are for explanatory purposes only and the shape of your unit may vary slightly from that which is shown in this manual.

DISPOSAL GUIDELINES

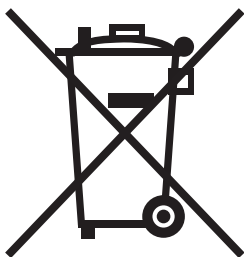

This appliance contains potentially hazardous materials. Do not dispose of this product as household waste or unsorted municipal waste. Local regulations may require special collection and treatment, confirm with your local municipal council which disposal options apply in your area.



Special notice – Disposing of this appliance in the forest or other natural surroundings and may endanger your health and is bad for the environment. Hazardous substances may leak into the ground water and enter the food chain.

The appliance can be operated conveniently in 3 different ways: manually, via the remote control handset or via the dedicated iOS/Android app (with Wi-Fi connectivity).

MANUAL CONTROL

Each time a button is pressed on the appliance or on the remote control an audible beep is emitted. To turn off this feature hold your finger on the Preset Mode button (on the appliance) for 3 Seconds.

Figure 1.

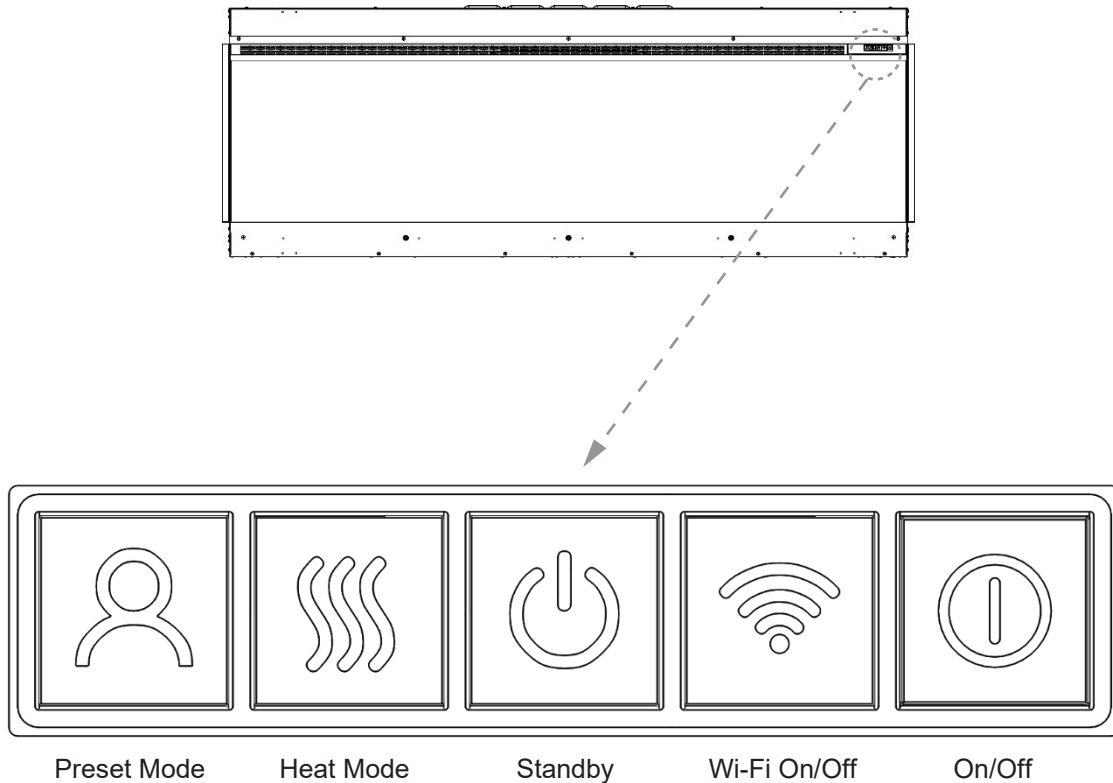

ON/OFF

Press to turn on power to the appliance. Button pushed in indicates power is on, button pushed out indicates power is off.

Wi-Fi On/Off

Press to turn Wi-Fi on or off. An illuminated LED on the button indicates that Wi-Fi is turned on. Hold button for 3 seconds to enter device pairing mode.

Standby

Turns on the appliance with the last used settings without any heat. Places the appliance into standby mode with all features turned off.

Heat Mode

1 press = cool blow. 2 press = low heat setting. 3 press = high heat setting. 4 press = no heat/no cool blow.

Preset Mode

Press repeatedly to cycle through the 6 fire preset modes (+3 user defined pre-sets if programmed).

REMOTE CONTROL



KEEP BATTERIES OUT OF REACH OF CHILDREN.

DO NOT

Mix old and new batteries.

Use different types of batteries at the same time.

Heat or expose to flame.

Take apart or short circuit.

Attempt to recharge alkaline batteries.

Use batteries of their covering has been damaged or peeled off.

Dispose of used batteries safety.

Remove batteries if controller is not used for long periods to help avoid damage from leaking batteries.

Ensure that 2 x AAA batteries are inserted into the remote control handset. The battery power level is indicated by the column of bars to the right side of the temperature display when the appliance is in standby mode. 5 bars indicates the batteries are full, 1 bar indicates the batteries are empty and need to be replaced immediately.

Remote Control Setup

Press and hold the Standby button on the appliance until you hear two beeps, release the button. Press Standby button on the remote control handset and you will hear one beep. The remote is connected with the appliance.

Button 1: Preset Mode

Repeatedly press to cycle through the 6 preset fire modes (+ 3 user defined presets if programmed).

On screen Pr.1 = Autumn Campfire

On screen Pr.2 = Ember Glow

On screen Pr.3 = Inferno

On screen Pr.4 = Noir

On screen Pr.5 = Fire & Ice

On screen Pr.6 = Nebula

On screen Pr.7 = User Preset

On screen Pr.8 = User Preset

On screen Pr.9 = User Preset

Figure 2. Remote Control Functions



The remote control handset must be left in the same room as the appliance as it houses the thermostat that regulates heat output.

There are 3 preset spaces allocated for the user to save personalised Electric Fire creations. Simply choose the flame colour and brightness level, the fuel bed colour and brightness level and fuel bed downlight colour and brightness level. Once you have selected your desired combination, press and hold the Preset Mode button for 3 seconds until the LCD displays FL.7. Press – and + buttons to select a slot number between 7-9. Press and hold the Preset Mode button for 3 seconds to confirm the preset.

Button 2: Standby

Turns on the appliance with the last used settings without any heat. Places the appliance into standby mode with all features turned off.

Button 3&9: Minus (–) & Plus (+)

Use to navigate through different on-screen menus.

Button 4: Flame Speed 

Press once to enter flame speed menu – SPd will show on the LCD screen. Press Plus and Minus buttons to adjust the flame speed. The flame speed is indicated on screen by bars – 1 bar is the slowest setting; 5 bars is the fastest.

Button 5: Flame Colour 

Repeatedly press to cycle through flame colour menu. Whilst in the flame colour menu, press the plus and minus buttons to increase and decrease the flame brightness - 1 bar is the dimmest setting, 5 bars is the brightest setting.

- On screen FL.0 = Flame off
- On screen FL.1 = Red
- On screen FL.2 = Orange
- On screen FL.3 = Yellow
- On screen FL.4 = Green
- On screen FL.5 = Light Blue
- On screen FL.6 = Dark Blue
- On screen FL.7 = Violet
- On screen FL.8 = White
- On screen FL.9 = Multi-colour change

Button 6: Fuel Bed Colour 

Repeatedly press to cycle fuel bed colour menu. From the fuel bed colour menu, press plus and minus buttons to increase or decrease the fuel bed brightness - 1 bar is the dimmest setting, 5 bars is the brightest setting.

- On screen Fb.0 = Flame off
- On screen Fb.1 = Red
- On screen Fb.2 = Orange
- On screen Fb.3 = Yellow
- On screen Fb.4 = Green
- On screen Fb.5 = Light Blue
- On screen Fb.6 = Dark Blue
- On screen Fb.7 = Violet
- On screen Fb.8 = White
- On screen Fb.9 = Multi-colour change

Button 7: Timer Mode 

Repeatedly press to cycle through timer options. Select an amount of time for the appliance to operate then automatically turn off. Choose between 0.5, 1, 2, 3, 4, 5, 6, 7, 8, 9 hours.

Button 8: Fuel Bed Downlight 

Repeatedly press to cycle fuel bed downlight colour menu. From the fuel bed down light colour menu, press plus and minus buttons to increase or decrease fuel bed brightness - 1 bar is the dimmest setting, 5 bars is the brightest.

- On screen dL.0 = Light off
- On screen dL.1 = Red
- On screen dL.2 = Orange
- On screen dL.3 = Yellow
- On screen dL.4 = Green
- On screen dL.5 = Light Blue
- On screen dL.6 = Dark Blue
- On screen dL.7 = Violet
- On screen dL.8 = White
- On screen dL.9 = Multi-colour change

Button 10: Heater Mode 

Press to cycle through the heat output options.

- 1 press: Co.A = Cool blow setting**
- 2 press: H.Lo = Low heat setting**
- 3 press: H.HI = High heat setting**
- 4 press: no.H = No Heat (heat off / standby)**

While in heater mode, after selecting low or high heat setting, press the – and + buttons to select the temperature you want the room to reach. Note: if the room temperature is already higher than the temperature selected, the heater will not activate. To switch between °C/°F hold down the – and + buttons for 3 seconds.

Open Window Detection is an innovative eco feature that detects a rapid drop in room temperature caused by an open window. The warning word "OPn" will be displayed on the screen and the heater will be turned off. If the room temperature rises or the remote control is operated manually, the heater will return to its normal working state.

Button 11: Sound Effect 

Press to open the sound effect menu.

- 1 press: S.on = Sound effect on**
- 2 press: no.S = Sound effect off**

While in the sound effect menu, press the plus and minus buttons to increase and decrease the volume - 1 bar is the quietest setting, 5 bars is the loudest setting.

Button 12: Ambient Lighting (Not available) **Button 13: Eco Mode** 

Press to activate Eco mode. This mode will reduce the brightness of all lighting modes and limit the heat output to low setting, resulting in reduced energy consumption. Press the button a second time to exit Eco mode.

WI-FI

Visit your device app store (iOS or Android) to download the TUYA SMART APP. Once installed follow the procedure below to pair the device with your appliance:

- Step 1. Start the app and click "Add Device". Select "Small Home Appliance", then select "Heater (Wi-Fi)".
- Step 2. Ensure the appliance is powered on then press and hold the button  on the appliance until you hear 3 beeps. At the same time the button will flash and the fuel bed will flash.
- Step 3. Follow the instructions on the app to input your home network details. Note, your device must also be connected to the same home network you wish to connect the appliance to.

Once connected you can fully control your appliance.

If the appliance still fails to turn on after 4 attempts, contact Rinnai as a service call may be required.

For further details, refer to the Wi-Fi Operation Manual. A copy of the manual may be downloaded from the Rinnai website: <http://www.rinnai.com.au/heating/>

CLEANING & REPAIRS

CLEANING



ALWAYS DISCONNECT THE APPLIANCE FROM THE POWER SUPPLY AND ALLOW TO COOL BEFORE CLEANING.

Your appliance needs very little maintenance, however it should be regularly cleaned using a dry cloth. Do not use detergents, abrasive cleaners or furniture polish.

To clean the glass, use a lightly damp cloth and ensure any moisture is dried fully using a lint free cloth.

Ensure the heater vent is kept dust free by regularly (monthly or more frequently) vacuuming the vent area with a brush attachment. This will keep it working efficiently.

REPAIRS

Repairs **MUST** be carried out by a qualified person such as an electrician.

TROUBLE SHOOTING CHECKLIST

Resetting the Thermal Cut Out

The appliance is fitted with an Electronic Safety Control (E.S.C). This is a safety device which switches off the fire if, for any reason, the appliance overheats, e.g. when covered. If the heater stops operating while the flame effect continues working normally, this indicates that the E.S.C is in operation. The E.S.C can only be reset after the appliance has cooled down and the appliance has been reset. Re-setting of the E.S.C Resetting procedure for the E.S.C is as follows:

1. Make sure that the power supply is disconnected with the plug socket outlet. Switch off the appliance via the On/Off switch on the Manual Control. Then leave it off for approximately 10-15 minutes.
2. Remove any obstruction to the fan heater outlet or fan blades etc.
3. Re-connect the power supply, and switch on the appliance and the E.S.C will be reset.
4. Ensure that the appliance is functioning correctly. If the E.S.C operates again, the appliance and wiring should be checked by a qualified person such as an electrician.

Use the following chart to help determine whether a service call is required. However, if you are unsure about the way your heater is operating, or if you have any other faults or problems, please refer to your installer or a Rinnai Customer Care Centre Consultant, see back page for Rinnai website and contact details.

Problem	Probable Cause	Suggested Remedy
Appliance will not turn on.	Problem with power supply.	Check that the appliance is plugged in to the power supply and switched on. Check and replace fuse in the plug if necessary. Check that the main power switch on the appliance is turned on.
Remote control does not work.	Batteries have expired.	Replace batteries.
	Remote has not synced with appliance.	Ensure that the appliance is turned on. Re-sync the remote by pressing the – button and the + button at the same time and holding for 3 seconds.
No heat.	Incorrect thermostat setting.	Increase the desired temperature higher than the current room temperature.
	Overheating may have engaged the E.S.C feature.	See above for E.S.C reset procedure.
Appliance turns off before desired temperature is reached.	Open window detection has activated.	Check that any windows in the room are closed.
	Remote Control is in unsuitable location.	Relocate remote control in the same room as the appliance.

INSTALLATION TABLE OF CONTENTS

Operation Table of Contents	3
General Installation Information	13
Installation Requirements	13
Unpacking the Appliance	13
Carton Contents / Item Checklist	13
Before You Start	14
Appliance Location	14
Clearances	14
Installation	15
Electrical Connections	15
GPO Connection	15
Heater Installation	15
Preparing the Appliance	15
Glass Removal - Accessing Parts	15
Removal of Wall Mounting Bracket	15
Power Cord	15
Aspect Type	16
One-Sided (Front) Aspect	16
Two-Sided (Corner) Aspect	16
Three-Sided Aspect	16
Installation Types	17
Wall Mounted	17
Shelf Mounted	17
Feature Wall	17
Finishing	18
Specifications	19
Product Specifications	19
Technical Information	20
Warranty	23
Contacts	28



For continued safety of this appliance it **MUST** be installed and maintained in accordance with the manufacturers instructions.

GENERAL INSTALLATION INFORMATION

INSTALLATION REQUIREMENTS

This appliance must be installed in accordance with this instruction manual.

UNPACKING THE APPLIANCE

Check for damage and missing parts. If the heater is damaged or missing any parts, contact your supplier for advice.

CARTON CONTENTS / ITEM CHECKLIST

Ensure that the components listed are present before proceeding with the installation.

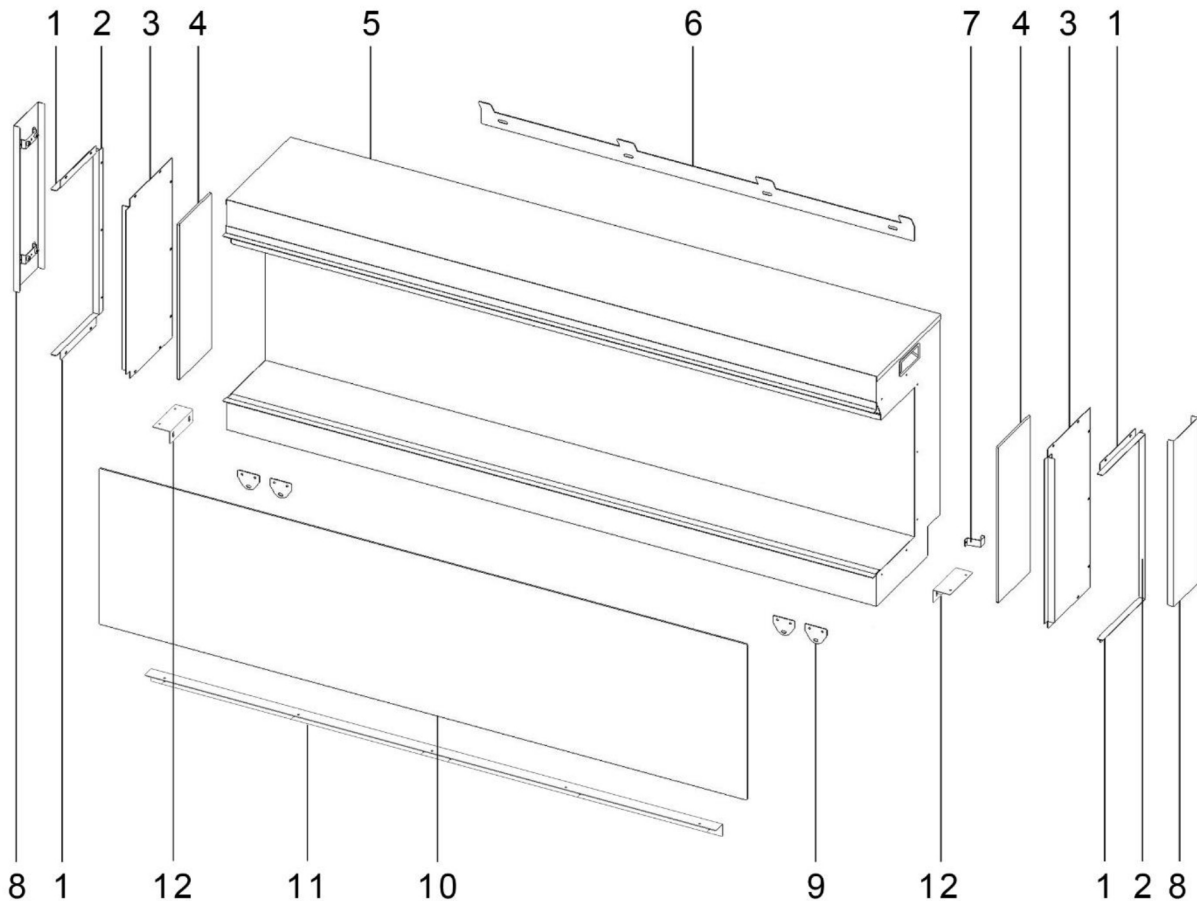

Item	Description	Qty	Item	Description	Qty
1	Side Glass Trim (Top/Bottom)	4	12	Shelf Support Bracket (Short)	2
2	Side Glass Trim (Side)	2	13 (*NS)	Orange Glass Suction Cup	2
3	Metal Side Panel	2	14 (*NS)	Magnet Tool	1
4	Side Glass Panel	2	15 (*NS)	Power Cord (1.8m)	1
5	Appliance Body	1	16 (*NS)	Remote Control Handset	1
6	Wall Mounting Bracket	1	17 (*NS)	AAA batteries	2
7	Power Cable Securing Bracket	1	18 (*NS)	ST4*8 Screw	19
8	Magnetic Side Decorative Panel	2	19 (*NS)	Decorative Fuel Logs	1 set
9	Small Mounting Bracket	4	20 (*NS)	Bag Of Glass Embers	1
10	Front Glass Panel	1	21 (*NS)	Bag Of Vermiculite Granules	1
11	Shelf Support Bracket (Long)	1	22 (*NS)	Instruction Manual	1
(*NS) = Not shown					

BEFORE YOU START

APPLIANCE LOCATION

The main considerations when positioning the heater are:

- Ensuring all minimum clearance requirements as shown are met.
- Allowing sufficient access for ease of operation, servicing and removal of the appliance.
- Ensuring the 3 pin plug is accessible and connected to a dedicated 240 V, 50 Hz, 10 Amp, earthed power point supplied from mains electricity. The connection of the appliance to a permanent electrical supply (hard-wiring) and the installation of any other electrical wiring, power outlets and switches **MUST** be performed by a person authorised under the legislation of your local electrical authority, such as a licensed electrician.
- Ensure any wall cavities above the heater are blocked off to avoid heat loss and poor heating performance. If installing in an existing fireplace, chimney or wall cavity, always block off the space above and around the heater to prevent heat loss and undesirable drafts. Failure to do this may cause the appliance to cut out.

CLEARANCES

The minimum clearances shown **MUST** be maintained.

Minimum Clearance to Combustibles (mm)		
Sides	0	No clearance required
Floor	0	
Back	0	
Top (shelf or TV)	200	
Front	915	

Dimensions for Cavity Installation					
Model	Recommended Cavity Dimensions (mm)*				
	H	W			D
		One-sided (a)	Two-sided (b)	Three-sided (c)	
ES750	858	786	768	750	301
ES1000	558	1036	1018	1000	301
ES1300	558	1336	1318	1300	301
ES1500	558	1536	1518	1500	301
ES1800	558	1836	1818	1800	301
ES2200	558	2236	2218	2200	301

*These dimensions are a guide. Always measure the appliance on site before cutting the cavity.

Figure 3. Clearance to Combustibles

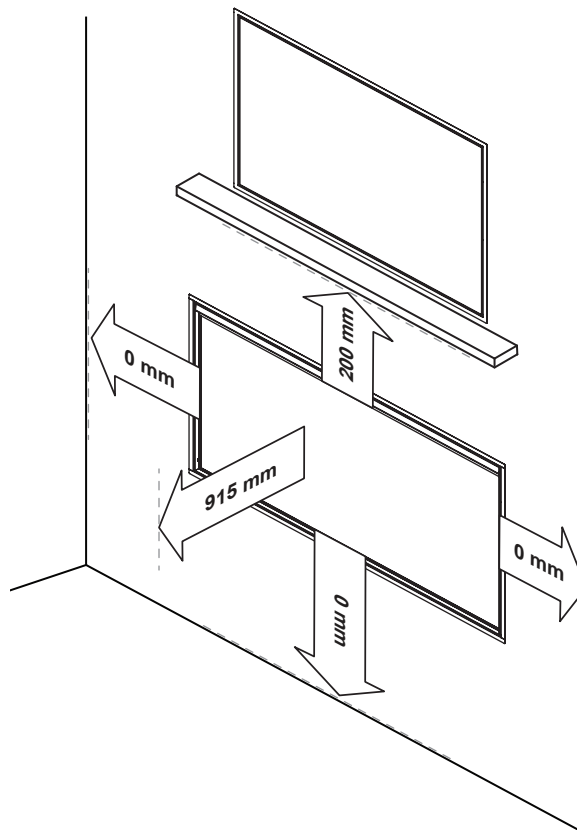
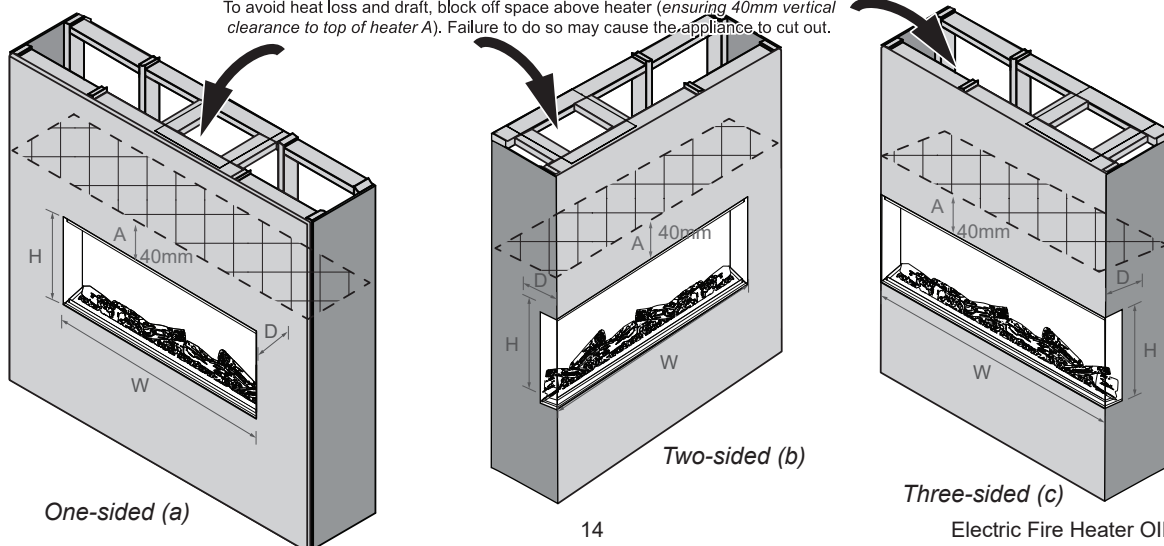

Figure 4. Cavity Dimensions

To avoid heat loss and draft, block off space above heater (ensuring 40mm vertical clearance to top of heater A). Failure to do so may cause the appliance to cut out.



INSTALLATION

ELECTRICAL CONNECTIONS

GPO Connection

The connection of the appliance to a permanent electrical supply (hard-wiring) and the installation of any other electrical wiring, power outlets and switches **MUST** be performed by a person authorised under the legislation of your local electrical authority, such as a licensed electrician.

HEATER INSTALLATION

Before installation, check that all parts are included and undamaged. If the appliance is damaged, check with the supplier before installation and operation. If the mains power supply lead is damaged in any way, it **MUST** be replaced by a suitable equivalent approved by the manufacturer.

The main box contains the appliance, 2 x suction cups and 1 x magnet tool. Packed with the appliance (behind the glass panel) are additional boxes each with a contents list printed on the outside of each box.

PREPARING THE APPLIANCE

Glass Removal - Accessing Parts

To gain access to various contents required for installation follow steps shown in "Figure 5." through to "Figure 8." to remove the glass panel on the front of the appliance.

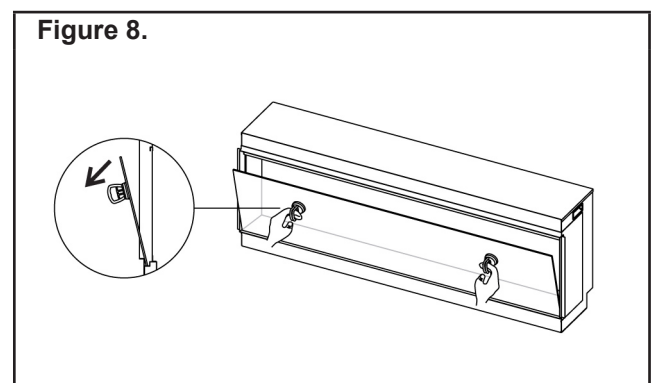
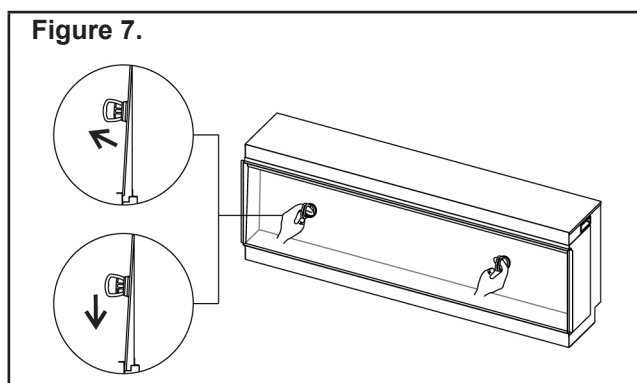
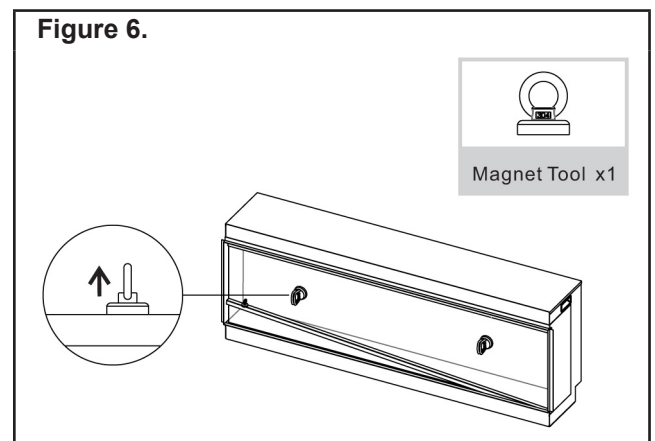
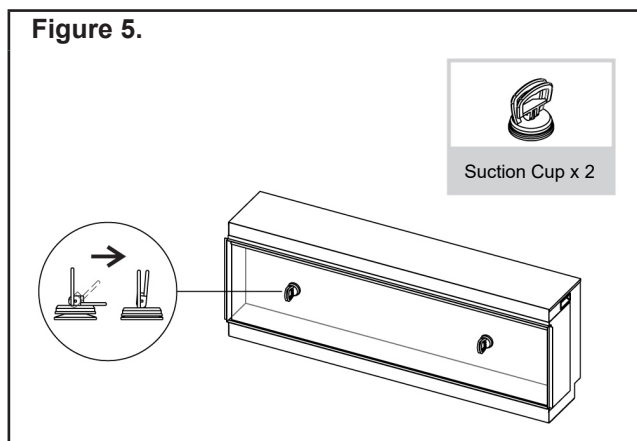

Removal of Wall Mounting Bracket

The wall mounting bracket is secured to the rear panel of the appliance. Remove the screws and the wall mounting bracket and put aside for later use. Refer to Figure 9 on page 16.

Power Cord

After inserting the 1.8m power cord into the socket on the bottom right side of the appliance, secure in place using the power cord securing bracket and ST4*8 screw (found inside Box #1). Refer to Figure 10 on page 16.



If not secured, the connection can become loose during installation which may present a hazard (sparking etc.)

Ensure the power cord is not squashed, kinked or in contact with hot or sharp surfaces.

Do not route the power lead in front of the appliance.

ASPECT TYPE

The appliance can be installed in three different aspects:

- Front (1 glass panel)
- Corner (2 glass panels)
- Three-sided (3 glass panels)

One-Sided (Front) Aspect

Your appliance will arrive in a single-sided (front only) aspect with metal side panels already fitted. Refer to Figure 11.

Two-Sided (Corner) Aspect

For a two-sided (corner) aspect, choose which side you want to feature a glass panel and remove the 7 screws that secure the metal side panel to the appliance. Refer to Figure 12. Carefully remove the panel and keep the screws in a safe place.

Using the removed screws, take 2 top/bottom side glass edge trims and 1 side of the side glass edge trim and screw them to the appliance as shown below. Refer to Figure 13.

Three-Sided Aspect

For a three-sided aspect, repeat the corner aspect procedure on the opposite side of the appliance. Refer to Figure 14.

Figure 9.

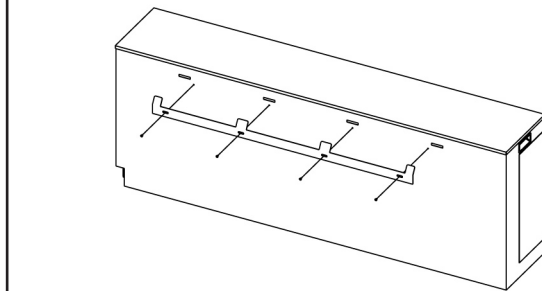

Figure 10.

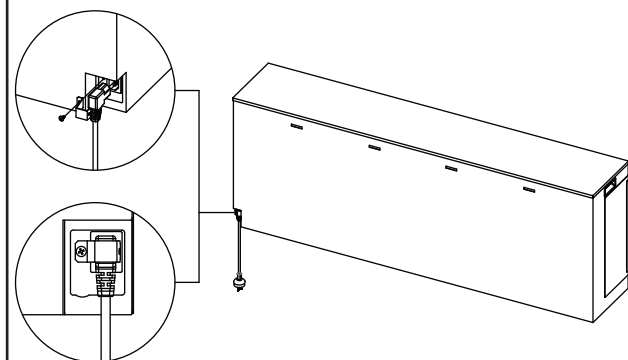

Figure 11.

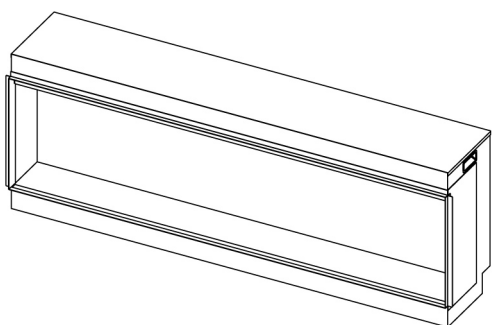

Figure 12.

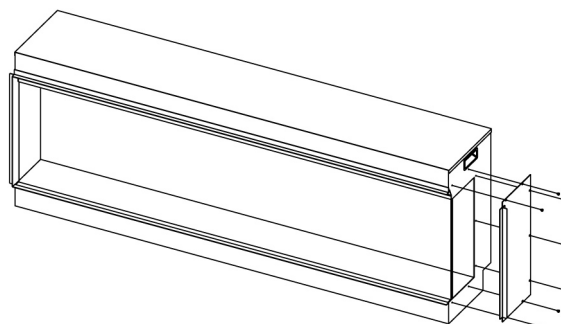

Figure 13.

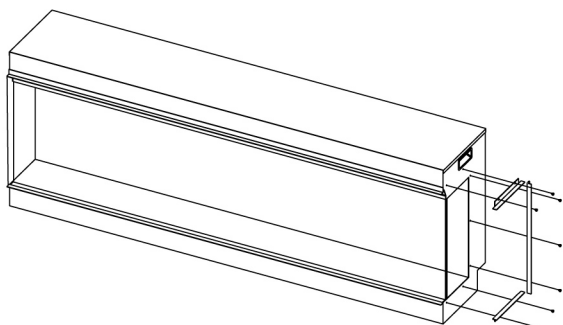
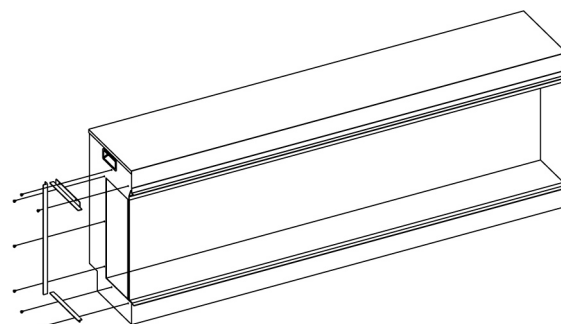

Figure 14.





The manufacturer does not accept any liability for any injuries or damages that may occur due to improper handling or installation. Ensure that the wall where the appliance is to be installed and any wall fixings used are sufficiently strong enough to hold the weight of the appliance. The appliance weight can be found printed on the packaging.

Plasterboard alone is not considered a structural material and it is not recommended to rely solely on plasterboard fittings to support the weight of the appliance.

If the appliance or any structure linked to the appliance is to be fitted to a wall with a timber frame construction, adequate wooden supporting members must be fitted using appropriate fixings. If this is not possible then steps must be taken to strengthen the wall before installation.

INSTALLATION TYPES

Wall Mounted

The appliance is supplied with a wall bracket which is secured to the rear of the appliance.

Step 1.

Remove the bracket from the rear of the appliance, place the bracket in the desired position ensuring it is level, mark the fixing points and use appropriate fixings to secure to the wall.

Step 2.

Attach the bottom mounting brackets to the appliance using x4 ST4 screws (see Figure 15). The appliance then can be lifted on to the wall bracket to enable the bottom bracket fixing points to be marked on the wall. Then use suitable fixings to secure the bottom mounting brackets to the wall.

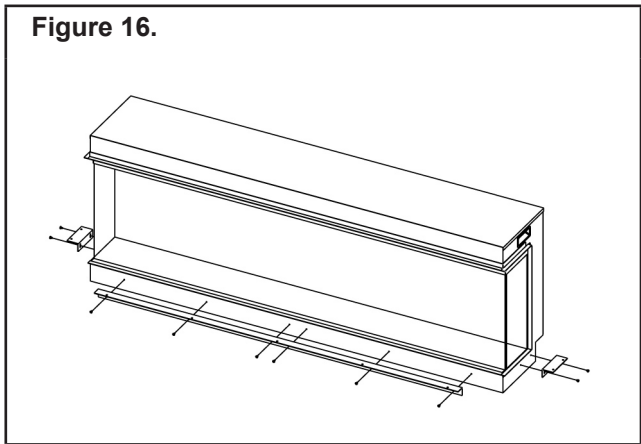
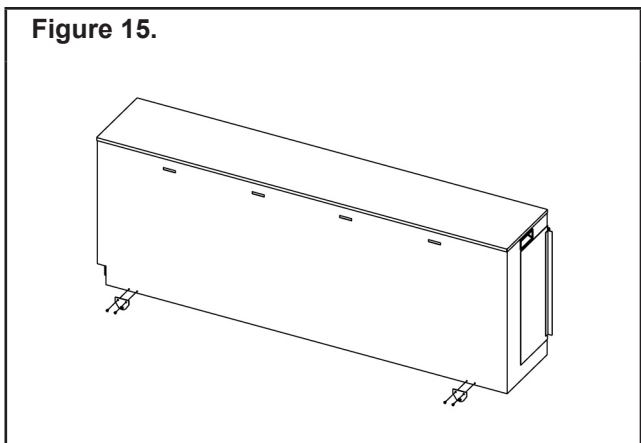

 See details of the weight of the appliance in the technical information to help determine the correct fixtures.

Shelf Mounted

The appliance can be fitted using the shelf support brackets. Refer to Figure 16. The brackets can be adjusted up or down to suit a range of shelf material thickness from 15-24mm. Once the correct thickness has been set, carefully place the unit onto the shelf.

Feature Wall

Ensure that the stud wall has a supporting header – the weight of the finished wall should not rest on the top of the appliance. The base of the stud work must be able to take the full weight of the appliance.

The 4 small mounting brackets can be fitted to the appliance as shown in Figure 17 for securing to a timber frame.

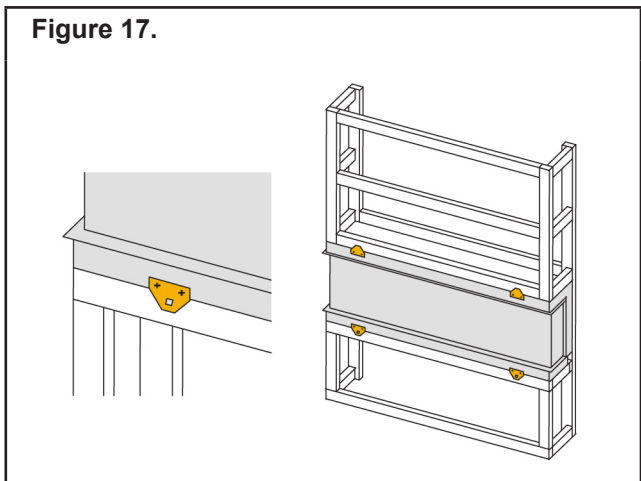

FINISHING

Magnetic Side Decorative Panels

The appliance is supplied with 2 magnetic panels that can be fitted when installing in a 2-sided, 3-sided aspect or corner aspect. These panels are simply positioned against the side of the appliance, behind the side glass edge trim (see Figure 18).

Log And Ember Arrangement

The logs can be arranged freely on the fire allowing you to create your own unique appearance. For the best results it is recommended to position the logs across the fuel bed first; experiment with position angles and overlapping the logs so that some rest on each other. Refer to Figure 19.

When you are satisfied with the layout, carefully scatter the glass embers around all the logs. Ensure that all visible areas of the fuel bed, including underneath and behind the logs are covered. Refer to Figure 20.

Lastly, in a similar manner, carefully scatter the vermiculite granules over the glass embers ensuring good coverage. Refer to Figure 21.

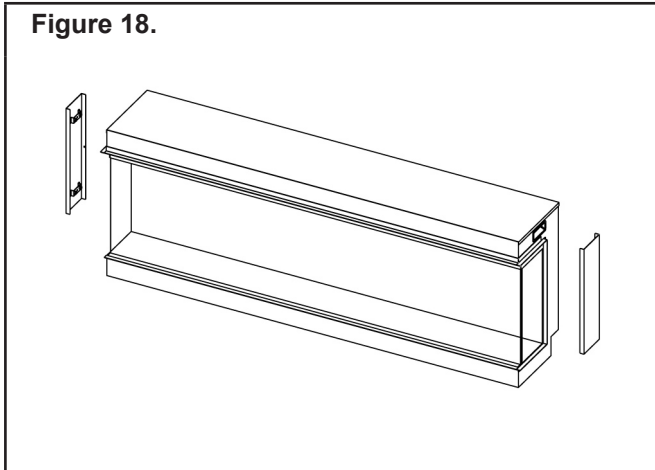

SPECIFICATIONS

PRODUCT SPECIFICATIONS

Model	Unit	ES750	ES1000	ES1300	ES1500	ES1800	ES2200
Weight	kg	47.5	44.5	54.3	59.3	70.8	87.0
Dimensions H x W x D	mm	848 x 780 x 296	548 x 1030 x 296	548 x 1330 x 296	548 x 1530 x 296	548 x 1830 x 296	548 x 2230 x 296
Mains Electricity Supply	VAC / Hz	230-240 / 50	230-240 / 50	230-240 / 50	230-240 / 50	230-240 / 50	230-240 / 50
Three Pin Plug Type	Amp	10	10	10	10	10	10
Length of Power Lead	mm	1600	1600	1600	1600	1600	1600
Max. Power Consumption	W	2000	2000	2000	2000	2000	2000
Power for Flame Effect	W	28	40	50	52	62	80

HEAT OUTPUT	SYMBOL	VALUE	UNIT
Nominal Heat Output	P _{nom}	2	kW
Minimum Heat Output	P _{min}	1	kW
Maximum Continuous Heat Output	P _{max}	2	kW

AUXILIARY ELECTRICITY CONSUMPTION			
At Nominal Heat Output	el _{max}	12.5	W
At Minimum Heat Output	el _{min}	12	W

TYPE OF HEAT OUTPUT / ROOM TEMPERATURE CONTROL	YES / NO
With electronic room temperature control	YES
Electronic room temperature control plus day timer	YES
Electronic room temperature control plus week timer	YES

OTHER CONTROL OPTIONS	YES / NO
Room temperature control, with open window detection	YES
With distance control option	YES
With adaptive start control	YES

SPECIFICATIONS

TECHNICAL INFORMATION

ES750

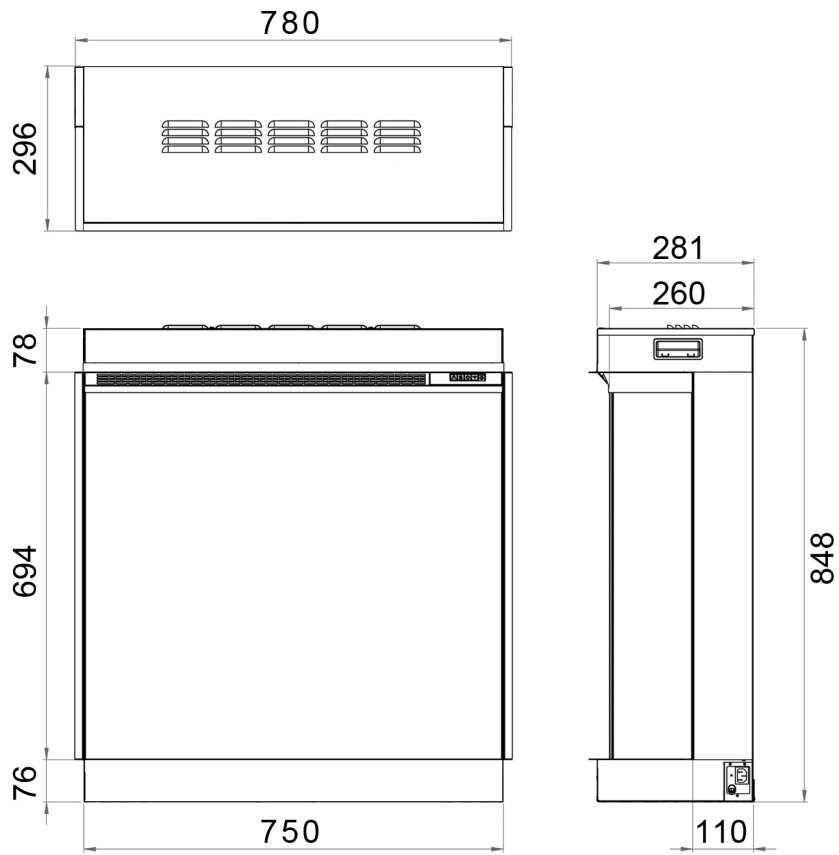

ES1000

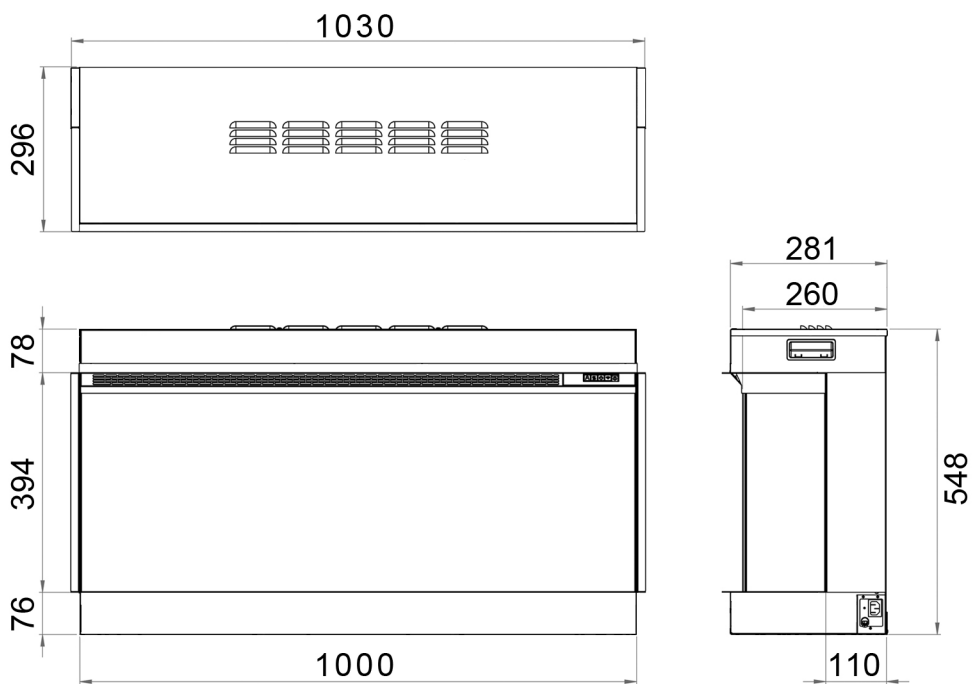

ES1300

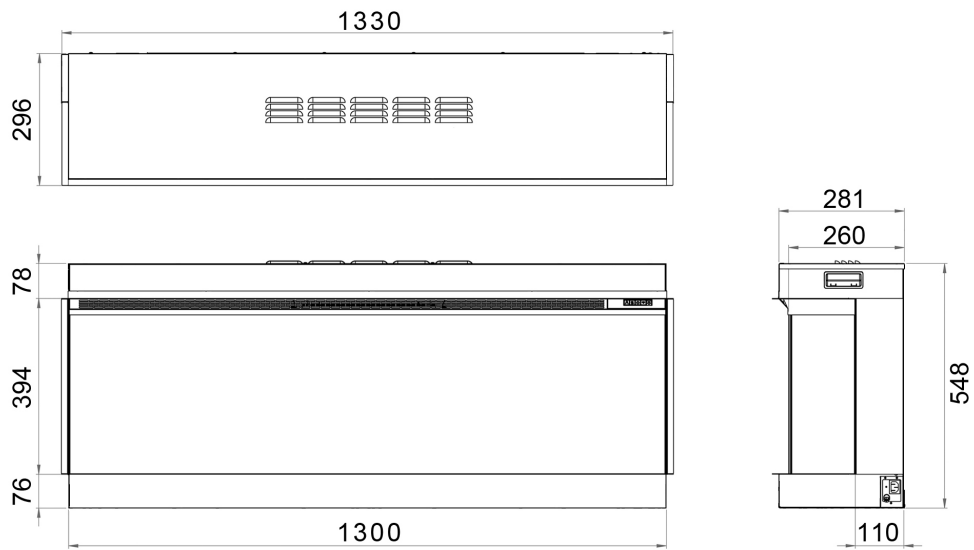

ES1500

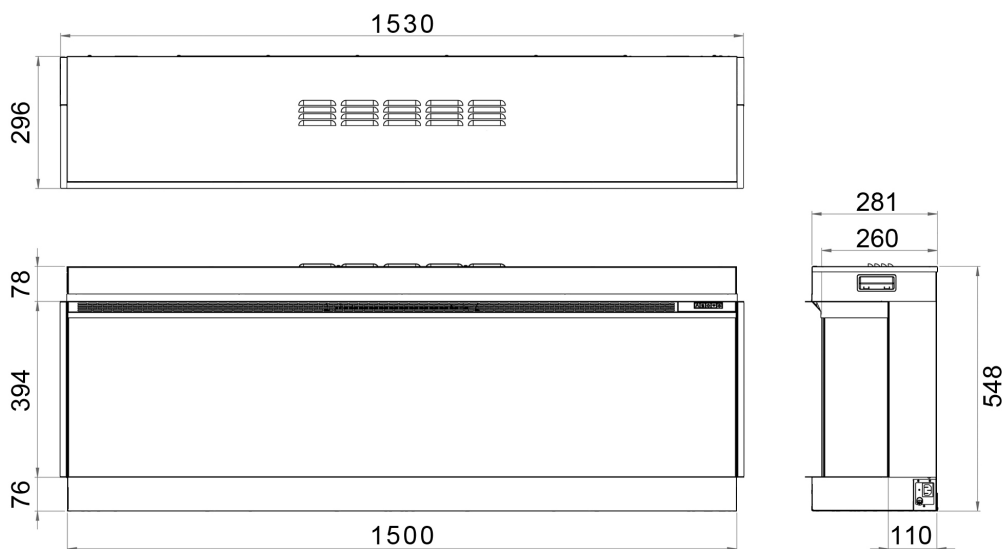

ES1800

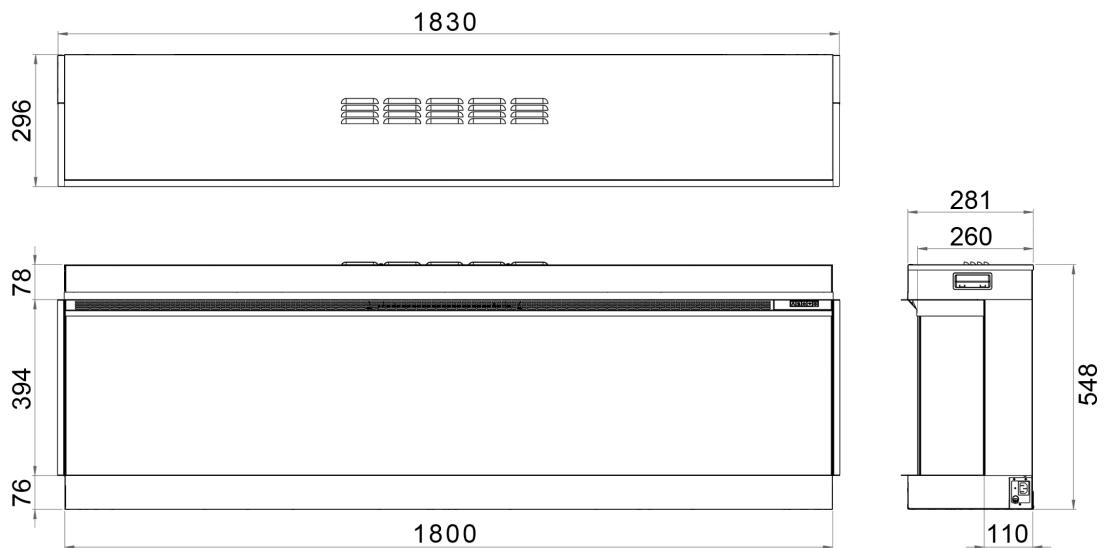

SPECIFICATIONS

ES2200

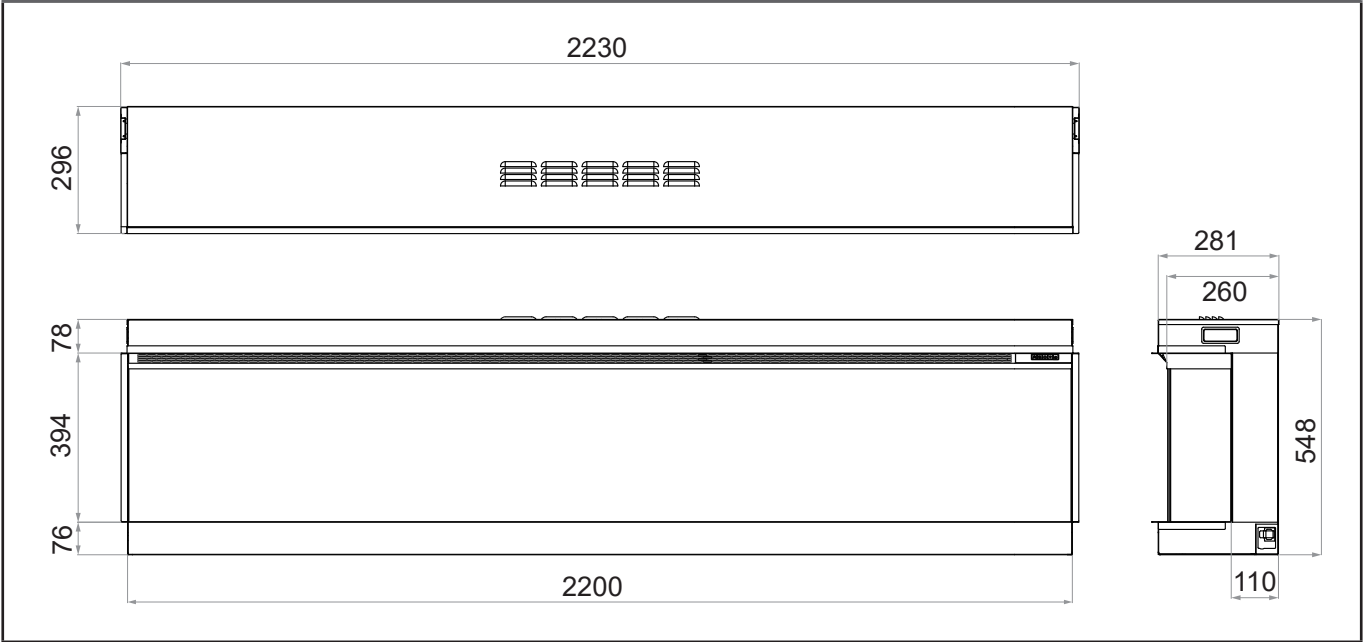

TERMS OF WARRANTY – AUSTRALIA

Rinnai Australia Pty. Ltd. ABN 74 005 138 769, 100 Atlantic Drive, Keysborough VIC 3173.

1 DEFINITIONS

The terms listed below shall have the following meanings:

- 1 **“Authorised Service Representative”** means an independent service contractor authorised by Rinnai or Rinnai service personnel.
- 2 **“Rinnai”** means Rinnai Australia Pty Ltd (ABN 74 005 138 769) and any related company.
- 3 **“Certificate(s) of Compliance”** means certificate(s) issued by licensed personnel (including plumbers, refrigeration mechanics, electricians or other relevant tradespeople) to certify that any prescribed works comply with applicable regulatory requirements.
- 4 **“Certificate(s) of Occupancy”** means certificate(s) issued by the local government authority (or similar organisation) which certifies that a home can be occupied.
- 5 **“Installation Site”** means the site at which the Product is originally installed.
- 6 **“Normal Business Hours”** means 8:30am to 5:00pm Monday to Friday, excluding public holidays.
- 7 **“Operating/Installation Instructions”** means the user manual or other documentation which provides detailed instructions on the proper operation and maintenance of the Product.
- 8 **“Other Applications”** means any Product used for purposes other than Residential & Light Commercial Applications. Other Applications may include but are not limited to factory, IT/Server room, telephone exchange, processing area (e.g. bakery, kitchen, warehouse, swimming pool, agricultural facilities such as a nursery). Any Product which has been installed, for whatever purpose, as a retrofit component to an existing system, will also be classed as being part of an “Other Application” regardless of the purpose of use of the existing system into which such product has been installed.
- 9 **“Purchaser”** means the end user of the Product, the person named as owner in the Warranty certificate, the holder of the Proof of Purchase or the holder of a property transfer document where the Product is included as part of the chattels.
- 10 **“Product”** means the equipment purchased by the Purchaser and described in Section 2 of this document.
- 11 **“Proof of Purchase”** means a Tax Invoice or Receipt in respect of the Product. In the case of new constructions, a Certificate of Occupancy or a Certificate of Compliance that details the date of installation or commissioning will suffice.
- 12 **“Qualified Installer”** means the qualified installation contractor who is responsible for performing the installation work in the manner prescribed by local and statutory regulations, including compliance with any relevant and to Rinnai specifications, including Australian Standards.
- 13 **“Residential & Light Commercial Applications”** means any Product for use in residential or light commercial applications where
 - a) the Product is solely used for the purpose of human comfort; and
 - b) the ambient temperature of the space the Product is intended to heat or cool is influenced solely or primarily by natural exterior weather conditions rather than by man-made or mechanical heat sources.

Examples of Residential & Light Commercial Applications include, homes, offices, hotels, apartments, nursing homes, hospitals, health care premises, shopping centres, and retail stores.

2 TERMS OF WARRANTY

2.1 Subject to the Terms of Warranty set out in this document, effective from the date of purchase by the Purchaser, the Product is warranted to be free from defects in materials & factory workmanship for the period set out in table below:

	PRODUCT GROUPS	PARTS	LABOUR
Residential and Light Commercial	Evaporative Coolers & Ducted Gas Heaters (excluding Compact Classic Series)	5 Years *Extended 4 Years Option	5 Years *Extended 4 Years Option
	Ducted Gas Heaters - Compact Classic Series	3 Years	3 Years
	Refrigerated Air conditioning Products	5 Years	5 Years
	Ducted Gas Heaters - Heat Exchangers and Burners Evaporative Coolers - Structural components only	10 Years	N/A
	Portable Air conditioning / Dehumidifier / Air Purifier	2 Years	N/A
	Electric Panel Heaters ⁽¹⁾	7 Years	N/A
	Electric Fire Heater	5 Years	5 Years
	Wi-Fi Devices	1 Year	1 Year
	Other Applications	All Product Groups	2 Years
After Market	Spare Parts	1 Year	N/A
*Extended Warranty Option	Up to 4 year extended warranty (in addition to the standard warranty period listed above) applies on selected products when you opt in to the Rinnai Service Advantage program. This program has terms and conditions, including the requirement for scheduled servicing of the product by Rinnai. To participate in the program you must register your product online at: www.rinnai.com.au/support-resources/warranty-registration/ within the first 12 months of the product being installed.		

⁽¹⁾ To make a claim under this warranty, please contact your place of purchase within the warranty period.

- 2.2 Rinnai will determine in its sole discretion, which classification the Product fits into and the corresponding Warranty that shall apply.
- 2.3 An Authorised Service Representative will repair or replace, at its option, the Product or any part of the Product that its examination shows to be defective. The repair or replacement shall be performed during Normal Business Hours by an Authorised Service Representative. Repair by persons other than an Authorised Service Representatives may void the Warranty.
- 2.4 Alternatively to clause 2.3 above, Rinnai can at its discretion elect to pay you an amount equivalent to the cost of repairing or replacing the Product.
- 2.5 If Rinnai provides you with either the replacement costs or replacement product, ownership of the original Product shall immediately transfer to Rinnai.
- 2.6 Rinnai is responsible for reasonable costs associated with legitimate warranty claims, including call-out of an Authorised Service Representative to inspect the Product. Rinnai is not responsible for:
 - a) costs for tradespeople engaged by you that are not Rinnai Authorised Service Representatives.
 - b) any costs, including call out costs for a Rinnai Authorised Service Representatives, associated with a Product which is determined upon inspection not to be covered by this warranty.
- 2.7 Rinnai will reimburse any reasonable costs associated with making a legitimate warranty claim against Rinnai which are not otherwise specified above.
- 2.8 The Warranty of the Product requires that, in addition to all other conditions, the Purchaser conducts regular and/or preventative maintenance as may be specified by the Operating/Installation Instructions or otherwise directed by Rinnai and required by the level of usage and the usage environment, including the use of correct and uncontaminated refrigerants and lubricants. Refrigeration, plumbing and electrical works must be undertaken by licensed personnel.
- 2.9 Where a Product or failed component is replaced under warranty, the time remaining on the original Product warranty period will continue to apply and the replacement product or part will be subject to the original warranty period only.

3 CONDITIONS OF WARRANTY

- 3.1 The Purchaser may only obtain the benefit of the Warranty if the Purchaser:
- maintains and has the Product serviced in accordance with the instructions set out in the service section of the relevant Service or Owner's Manual;
 - complies with clause 7 "Purchaser's Responsibilities" on page 26;
 - notifies Rinnai within 30 days of a defect occurring or, in the case of a latent defect, becoming apparent, that a claim is being made under this Warranty; and
 - provides, in support of the claim made under this Warranty, a Proof of Purchase.
- 3.2 This document (and any statutory consumer guarantees) represents the only Warranty given by Rinnai in respect of the Product. No other person or organisation is authorised to offer any alternative warranty on behalf of Rinnai.
- 3.3 If the date of purchase cannot be established to Rinnai's satisfaction, the date shall be deemed to be 2 months after the date of manufacture or the date of sale by Rinnai, whichever is the latter.
- 3.4 This warranty applies to Products which are manufactured on or after the date of publication of this warranty but before the next date of publication of this warranty.

4 EXCLUSIONS

- 4.1 This Warranty **does NOT** cover:
- damage, problems or failure resulting from improper operation and/or inadequate maintenance by the Purchaser (refer Purchaser's Responsibilities section below);
 - damage, problems or failure resulting from improper or faulty installation. The Product must be installed by a Qualified Installer in accordance with applicable regulations. Where applicable, Certificate(s) of Compliance must be obtained by the purchaser from the Qualified Installer and presented to the Authorised Service Representative;
 - damage, problems or failure caused by factors external to the Product including, but not limited to, faulty or poor external electrical wiring, incorrect or faulty power supply, voltage fluctuations, over voltage transients or electromagnetic interference, inadequate or faulty gas, drainage services, or water services, including water pressure, and non-potable water;
 - damage, problems or failure caused by acts of God, fire, wind, lightning, flood, storm, hail storm fallout, vandalism, earthquake, war, civil insurrection, misuse, abuse, negligence, accident, pests, animals, pets, vermin, insects, spiders/bugs or entry of foreign objects or matter into the Product such as dirt, debris, soot or moisture;
 - damage, problems or failure caused by environmental conditions including, but not limited to, excessive moisture, salt or other corrosive substances or atmospheric conditions;
 - Product which has been installed in a portable or mobile building, structure or application including, but not limited to, a caravan, boat or trailer;
 - Product which has been re-installed at a location other than the original site;
 - any consumable item supplied with the Product including, but not limited to, an air filter, battery, fan belt, igniter or cooler pad;
 - installation of third-party components that may be attached to the Product. These include, but are not limited to, control wiring, ducting, return air filter(s) grille, register, diffuser, zone motors, controls/thermostats, pipe work and fabricated or added components. These items remain solely the responsibility of the Qualified Installer;
 - installations where electrics/electronics may be subjected to moisture/chemicals (e.g. swimming pools or nurseries);
 - any repair, which is needed as a result of an accident, misuse, abuse or negligence;
 - Product that is utilised in an environment (indoor and outdoor) outside its specified operating range; and
 - fair wear and tear to the Product.
 - On-site labour warranty on portable (non-fixed installation) Products – In respect of such Products the Purchaser must return the Product to the supplier for repair or replacement).

5 LIMITATIONS

- 5.1 Third parties are often involved in providing advice to consumers about the climate control solutions best suited to the consumer's needs. Any advice or recommendations given by such parties, including advice about Product fitness for purpose and overall system design, sizing and application are not the responsibility of Rinnai. This includes but is not limited to the heat load calculations, airflow and system balancing.
- 5.2 This Warranty does not apply to any Product installed at an Installation Site which is outside Australia.
- 5.3 Except where inconsistent with the purchaser's statutory rights and the rights given by this Warranty, all liabilities of Rinnai for any direct, special, indirect or consequential loss or damage, any damage or expense for personal injury or any loss or destruction of property, arising directly or indirectly from the use or inability to use the Product or any of its parts and/or servicing the Product, are expressly excluded.

6 TRAVEL, TRANSPORT & ACCESS COSTS

- 6.1 The Purchaser must pay freight charges, in-transit insurance expenses and travelling costs for repairs/replacements under this Warranty, that are required to be performed 50km from the nearest Rinnai branch or Authorised Service Representative.
- 6.2 Subject to clause 6.3, Rinnai will pay freight charges, in-transit insurance expenses and travelling costs for repairs/replacements that are required to be performed less than 50km from the nearest Rinnai branch or Authorised Service Representative, subject to the following:
- Rinnai will arrange for such repairs/replacements and make any payment directly to the third party to provide the freight, in-transit insurance or travel services; or
 - if Rinnai considers appropriate, it will authorise the Purchaser in writing to pay for the relevant freight charges, in-transit insurance expenses or travelling costs and then, upon provision by the Purchaser to Rinnai of a tax invoice showing those costs have been incurred, reimburse the Purchaser for such costs which are within the terms of the authorisation. If the Purchaser pays for the relevant freight charges, in-transit insurance expenses or travelling costs without written authorisation from Rinnai, Rinnai will not reimburse the Purchaser for such costs.
- 6.3 The Purchaser must pay all costs and expenses in respect of:
- any service call out fee if the Product is not accessible for service
 - making the Product accessible for service, for example, restricted access or working at heights, or the labour cost for an additional person due to OHS requirements.
 - providing a safe working environment for installation, service, maintenance or repair of the Product;
 - any surcharge applicable in respect of supplying replacement parts outside Normal Business Hours; and
 - any other costs and expenses in relation to claiming the Warranty that is not covered by clause 6.2.

7 PURCHASER'S RESPONSIBILITIES

- 7.1 The Purchaser must operate and maintain the Product in accordance with the Operating Instructions and service maintenance schedule, including conducting an appropriate number of services to the unit during the Warranty period, based on usage and the usage environment including but not limited to;
- regularly cleaning the air filter(s) and replacing them where necessary;
 - replacing expired batteries or other consumables as required;
 - ensuring that the condensate drain is kept clean and clear of obstructions.

HOW TO MAKE A WARRANTY CLAIM:

If you wish to make a warranty claim in respect of any Portable Product, please return it to the place of purchase, or if that is not possible, contact Rinnai to enquire about alternative arrangements.

If you wish to make a warranty claim in respect of any fixed Product, please contact Rinnai on the details set out below to make arrangements for an Authorised Service Representative to inspect the product.

As per clause 2.6 of the Terms and Conditions of Warranty, purchasers are responsible for the costs of any repair and/or call out fee where, on inspection, the alleged defect is found by Rinnai's Authorised Service Representative not to be covered by this warranty or any statutory consumer guarantee applicable to the Product.

The Terms and Conditions of Warranty contain important information about your rights and obligations under this warranty. Please read them fully and carefully before making a claim.

NOTICE TO CONSUMERS UNDER AUSTRALIAN CONSUMER LAW

Our goods and services come with guarantees that cannot be excluded under the Australian Consumer Law.

For a major failure with a good, you are entitled to a replacement or refund and compensation for any other reasonable foreseeable loss or damage. If the failure does not amount to a major failure and if the goods fail to be of acceptable quality, you are also entitled to have the goods repaired or replaced.

For a major failure with the service, you are entitled to cancel your service contract with us and obtain a refund for the unused portion, or to compensation for its reduced value. You are also entitled to be compensated for any other reasonably foreseeable loss or damage. If the failure does not amount to a major failure you are entitled to have problems with the service rectified in a reasonable time and, if this is not done, to cancel your contract and obtain a refund for the unused portion of the contract.

The benefits provided by this Warranty are in addition to any other rights and remedies available to a consumer under the Australian Consumer Law and any other law which may apply to the goods and or services.

NOTES



Rinnai Australia Pty Ltd

ABN 74 005 138 769 | AU45204

100 Atlantic Drive, Keysborough, Victoria 3173
P.O. Box 460, Braeside, Victoria 3195
Tel: (03) 9271 6625
Fax: (03) 9271 6622

National Help Line

Tel: 1300 555 545* Fax: 1300 555 655
Monday to Friday, 8.00 am to 5.00 pm EST.

**Cost of a local call may be higher from a mobile phone.
(National calls from public phones in Australia are free.)*

For further information visit **www.rinnai.com.au**
or email **enquiry@rinnai.com.au**

Rinnai has a Service and Spare Parts network with personnel who are fully trained and equipped to give the best service on your Rinnai appliance. If your appliance requires service, please call our National Help Line.

With our policy of continuous improvement, we reserve the right to change, or discontinue at any time, specifications or designs without notice.